

## Steam Traps

### Thermostatic Steam Trap

(Non-Repairable)

**WT2000**  
Thermostatic

Model	<b>WT2000 (Non-Repairable)</b>
Sizes	<b>1/2", 3/4"</b>
Connections	<b>NPT</b>
Body Material	<b>Stainless Steel</b>
PMO Max. Operating Pressure	<b>650 PSIG</b>
TMO Max. Operating Temperature	<b>Saturated Steam Temp.</b>
PMA Max. Allowable Pressure	<b>1032 PSIG @ 100°F</b>
TMA Max. Allowable Temperature	<b>750°F @ 800 PSIG</b>

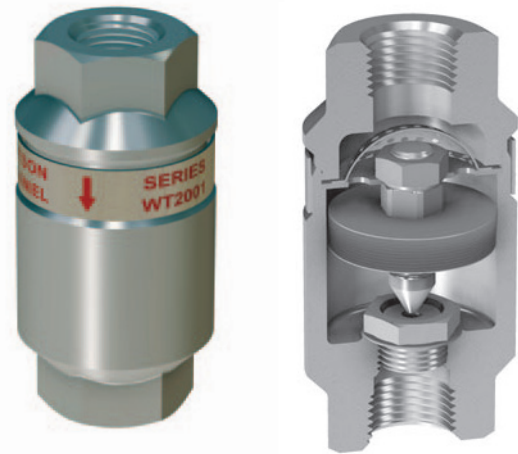

#### Typical Applications

**DRIP, TRACING, PROCESS:** The **WT2000** is a general purpose medium-capacity thermostatic trap that can be used for steam tracing, as a drip trap on steam mains and steam supply lines, as well as for process applications. They are also commonly used as an Air Vent on heat exchangers or at the ends of steam mains. Thermostatic traps are small, light weight, operate over a wide pressure range, and have excellent air handling capabilities. Discharging air at start-up allows steam to quickly enter the system. All stainless steel construction and integral strainer, make the WT2000 an excellent choice for a variety of applications. Trap body is permanently seal welded together and therefore non-repairable. Contains an extremely strong and rugged precision welded Stainless Steel thermal element which is highly resistant to waterhammer.

#### How It Works

This thermostatic trap contains a welded stainless steel thermal element that expands when heated and contracts when cooled to 5°F below saturated steam temperature. When air or sub-cooled condensate are present, the trap is in the open discharge position. When steam reaches the trap, the element expands and closes off tightly.

#### Features

- Thermostatic traps are excellent at discharging air, which allows steam to enter quickly; extremely important during start-up
- Integral strainer to protect trap from contamination
- Welded stainless steel thermal element resists shock from waterhammer
- Freeze-proof when trap is installed in a vertical orientation allowing for complete condensate drainage
- Body is produced from stainless steel investment casting
- Hardened stainless steel seat for extended service life
- Will operate at steam pressures up to 650 PSIG

#### Sample Specification

Steam trap shall be of thermostatic type with stainless steel body, thermal element, internal screen, and hardened valve and seat.

#### Installation and Maintenance

Trap can be installed in any position. The WT2000 steam trap body is seal-welded and therefore non-repairable. If a new trap is required, remove from line and replace. Cannot be welded in-line or failure of the thermal element may occur. Available in NPT threaded connections only.

#### Helpful Selection Information

Two orifice sizes are available: The 3/16" orifice should be used on all drip and tracing applications as well as small process applications with lower condensate loads. The 5/16" orifice is available to be used on process applications if additional capacity is required.

#### Options

- Special Bellows Option; available upon request:
  - Fail-closed Bellows (standard bellows fails in open position)
  - 43°F Sub-cool Bellows (Note: Standard bellows are designed for approximately 5°F sub-cool temperature)
- **SLR** = Steam lock release
- Standard models contain a non-cleanable strainer screen. Also available without screen where it is desirable to flush dirt and scale thru the trap. Recommend WT2003 with larger orifice if used without strainer.

# Steam Traps

## Thermostatic Steam Trap (Non-Repairable)

**WT2000**  
Thermostatic

STEAM TRAPS

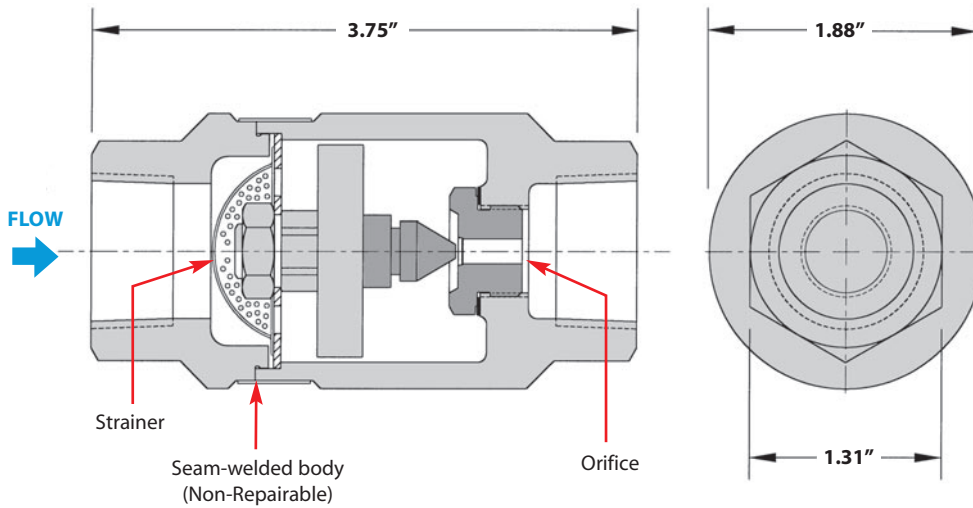

Weight: 1.5 lbs.

### MATERIALS

Trap Housing	Stainless Steel, ASTM A351-CF3
Thermal Element	Stainless Steel
Valve & Seat	Stainless Steel, AISI 416
Strainer Screen	Stainless Steel

### How to Size / Order

Select working pressure; follow column down to correct capacity (lbs/hr) block. Example:

Application: 1827 lbs/hr at 100 PSIG working inlet pressure

Size/Model: **WT2001-12-N**, 1/2" NPT, 3/16" orifice

### CAPACITIES — Condensate (lbs/hr)

Size	Model Code	Orifice Size	Steam Inlet Pressure (PSIG)														
			5	10	20	50	100	125	150	200	250	300	350	400	500	600	650
1/2"	WT2001-12-N	3/16"	441	625	882	1391	1827	1969	2095	2305	2483	2636	2777	2903	3129	3323	3413
3/4"	WT2001-13-N		903	1271	1811	2861	3754	4043	4300	4730	5093	5413	5702	5959	6421	6820	7004
1/2"	WT2003-12-N	5/16"	903	1271	1811	2861	3754	4043	4300	4730	5093	5413	5702	5959	6421	6820	7004
3/4"	WT2003-13-N		903	1271	1811	2861	3754	4043	4300	4730	5093	5413	5702	5959	6421	6820	7004

**Note:** 3/16" orifice should be used on all drip and tracing applications.

Back Pressure as Percentage of Inlet Pressure	10	20	25	30	40	50	60	70	80	90
Percentage Decrease in Trap Capacity	0	0	0	2	5	12	20	30	40	55