

Steam Traps

Float & Thermostatic Steam Trap

WFT Series

Float & Thermostatic

Model	WFT
Sizes	3/4", 1", 1 1/4", 1 1/2", 2"
Connections	NPT
Body Material	Cast Iron
PMO Max. Operating Pressure	250 PSIG
TMO Max. Operating Temperature	Saturated Steam Temperature
PMA Max. Allowable Pressure	250 PSIG up to 450°F
TMA Max. Allowable Temperature	450°F @ 250 PSIG



Typical Applications

PROCESS, DRIP: WFT Series with parallel port connections were specifically designed for removing condensate and air from HVAC and industrial process applications such as unit heaters, pressing machines, heat exchangers and coils. They contain a high-quality welded stainless steel thermostatic air vent and stainless steel mechanism. The WFT Series are fully repairable while the trap remains in-line and are available in 3/4" thru 2" NPT connections. For drip applications, such as draining steam mains and steam supply lines, use model 3/4" WFT-125 (WFT-125-13-N).

How It Works

Float and thermostatic traps contain a float-operated valve and seat mechanism with a separate thermostatic element which work together to remove both condensate and air from the steam system. The float, which is attached to a valve, rises and opens the valve when condensate enters the trap, allowing the condensate to discharge. Air is discharged through the thermostatic air vent to the outlet side of the trap. Steam entering the trap causes the thermostatic element to expand, closing the air vent and trapping the steam.

Features

- All stainless steel internals with hardened seat and wear parts
- In-line repairability is simplified by having all internals attached to the cover
- Welded stainless steel thermostatic air vent resists shock from waterhammer. Live orifice air vent is available for superheated applications
- Excellent air handling capability allows air to be discharged rapidly so steam can enter the system quickly during start-up
- F&T traps discharge condensate immediately as it is formed (no condensate will back up into the system)

Sample Specification

The trap shall be of float and thermostatic design with cast iron body and parallel piping configuration. Thermostatic air vent to be welded stainless steel. All internals must be stainless steel with hardened seat area. Trap must be in-line repairable.

Installation and Maintenance

The trap must be installed upright and level for the float mechanism to operate properly. All internal components can be replaced with the trap connected in-line. Repair kits include thermostatic air vent, float, valve seat and disc, and gaskets. The standard thermostatic air vent can be damaged by superheat; therefore, in applications with superheated steam, the thermostatic air vent should be replaced with a special "live orifice" air vent.

Options

- Live orifice air vent for superheated steam applications.
- NPT Connection for freeze protection
- **SLR** = Steam lock release
- **VB** = Vacuum Breaker
- **DP** = Drain Plug

MATERIALS

Body & Cover	Cast Iron
Gasket	Grafoil
Cover Screws	Steel, GR5
Float	Stainless Steel, AISI 304
Internals	Stainless Steel, 300 Series
Thermostat	Stainless Steel
Valve Seat	Stainless Steel, 17-4 PH
Valve Disc	Stainless Steel, AISI 420F

Demonstration of Parallel piping connections:

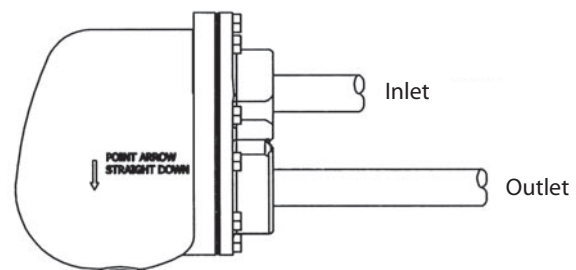

How to Size / Order

The **Maximum Operating Pressure (PMO)** rating of model selected must meet or exceed the maximum steam pressure or the trap may not open. For example; the WFT-125 has a PMO of 125 psi. Condensate capacity (lbs/hr) of the trap is based on the differential pressure across the trap.

For Drip Applications: a 3/4" WFT size is generally sufficient to exceed warm-up loads with a 2X safety factor.

For process applications: The condensate loads (lbs/hr) are normally calculated at the maximum steam pressure; then an appropriate safety margin is applied in order to select a trap with sufficient capacity when operating at lower steam pressures. Reference full explanation of Safety Load Factors in Steam Trap Introduction section.

When a temperature control valve regulates the flow of steam to the process equipment (Heat Exchanger) being drained of condensate, it is recommended to select a trap with a PMO that exceeds the inlet steam pressure to the temperature control valve. This assures that under all operating conditions, the steam pressure will not exceed the PMO of the trap.

For Example: Process application has a maximum steam inlet pressure of 100 psi, a maximum condensate load of 2,500 lbs/hr and is discharging to a condensate return line with a possible back pressure of 25 PSIG. $\Delta P = 100 - 25 = 75$ PSI

To select trap: If the Safety Load Factor is chosen to be 2X max capacity at max differential pressure, then Trap should be selected based on 5,000 lbs/hr (2,500 x 2 = 5,000) at 75 PSI differential pressure with a PMO in excess of 100 PSIG

Selection: **WFT-125-17-N**, PMO=125 PSIG, 2" NPT with a condensate capacity of 7,460 lbs/hr at 75 PSI differential pressure.

CAPACITIES – Condensate (lbs/hr)

Model Code	PMO (PSIG)	Pipe Size	Orifice Size	$\Delta P = \text{Differential Pressure (PSI)}$																		
				1/4	1/2	1	2	5	10	15	20	30	40	50	75	100	125	150	175	200	225	250
WFT-015-13-N	15	3/4"	0.250	390	490	620	780	1050	1320	1500												
WFT-015-14-N	15	1"	0.250	390	490	620	780	1050	1320	1500												
WFT-015-15-N	15	1 1/4"	0.312	610	770	960	1210	1630	2040	2330												
WFT-015-16-N	15	1 1/2"	0.500	1420	1910	2570	3460	5120	6890	8190												
WFT-015-17-N	15	2"	0.625	2260	2950	3860	5040	7170	9360	10930												
WFT-030-13-N	30	3/4"	0.228	330	420	530	670	930	1180	1350	1500	1720										
WFT-030-14-N	30	1"	0.228	330	420	530	670	930	1180	1350	1500	1720										
WFT-030-15-N	30	1 1/4"	0.228	330	420	530	670	930	1180	1350	1500	1720										
WFT-030-16-N	30	1 1/2"	0.390	930	1240	1650	2190	3210	4280	5060	5700	6750										
WFT-030-17-N	30	2"	0.500	1420	1910	2570	3460	5120	6890	8190	9260	11020										
WFT-075-13-N	75	3/4"	0.166	175	225	295	385	545	705	825	920	1075	1200	1305	1525							
WFT-075-14-N	75	1"	0.166	175	225	295	385	545	705	825	920	1075	1200	1305	1525							
WFT-075-15-N	75	1 1/4"	0.312	640	850	1130	1500	2180	2900	3420	3850	4540	5110	5600	6610							
WFT-075-16-N	75	1 1/2"	0.312	640	850	1130	1500	2180	2900	3420	3850	4540	5110	5600	6610							
WFT-075-17-N	75	2"	0.422	1020	1340	1760	2310	3330	4380	5140	5760	6770	7590	8290	9730							
WFT-125-13-N	125	3/4"	0.128	105	135	180	235	340	445	525	585	690	770	845	990	1110	1210					
WFT-125-14-N	125	1"	0.128	105	135	180	235	340	445	525	585	690	770	845	990	1110	1210					
WFT-125-15-N	125	1 1/4"	0.250	410	540	710	930	1340	1770	2070	2320	2730	3050	3340	3920	4390	4790					
WFT-125-16-N	125	1 1/2"	0.250	410	540	710	930	1340	1770	2070	2320	2730	3050	3340	3920	4390	4790					
WFT-125-17-N	125	2"	0.332	720	960	1270	1690	2460	3270	3860	4340	5130	5770	6320	7460	8390	9190					
WFT-175-13-N	175	3/4"	0.166	190	250	320	420	590	770	900	1010	1180	1310	1430	1670	1870	2030	2180	2310			
WFT-175-14-N	175	1"	0.166	190	250	320	420	590	770	900	1010	1180	1310	1430	1670	1870	2030	2180	2310			
WFT-175-15-N	175	1 1/4"	0.250	410	540	710	930	1340	1770	2070	2320	2730	3050	3340	3920	4390	4790	5150	5470			
WFT-175-16-N	175	1 1/2"	0.250	410	540	710	930	1340	1770	2070	2320	2730	3050	3340	3920	4390	4790	5150	5470			
WFT-175-17-N	175	2"	0.281	520	680	900	1180	1700	2230	2620	2930	3440	3860	4210	4950	5540	6050	6510	6920			
WFT-250-13-N	250	3/4"	0.128	115	145	190	245	345	450	520	580	675	755	820	955	1060	1155	1235	1310	1375	1440	1495
WFT-250-14-N	250	1"	0.128	115	145	190	245	345	450	520	580	675	755	820	955	1060	1155	1235	1310	1375	1440	1495
WFT-250-15-N	250	1 1/4"	0.203	270	350	450	590	820	1070	1240	1380	1600	1780	1940	2250	2500	2720	2910	3080	3240	3380	3520
WFT-250-16-N	250	1 1/2"	0.203	270	350	450	590	820	1070	1240	1380	1600	1780	1940	2250	2500	2720	2910	3080	3240	3380	3520
WFT-250-17-N	250	2"	0.250	410	540	710	930	1340	1760	2060	2310	2710	3040	3320	3890	4360	4760	5110	5430	5730	6000	6250

Steam Traps

Float & Thermostatic Steam Trap

WFT Series

Float & Thermostatic

Dimensions: inches



WFT
3/4" • 1" • 1 1/4"



WFT
3/4" & 1"

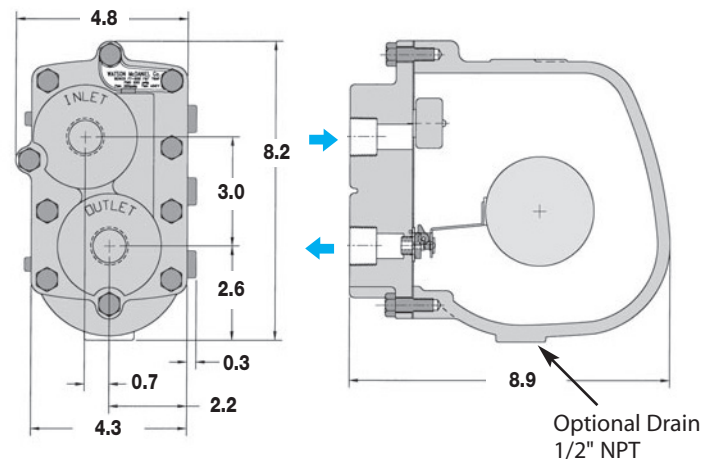
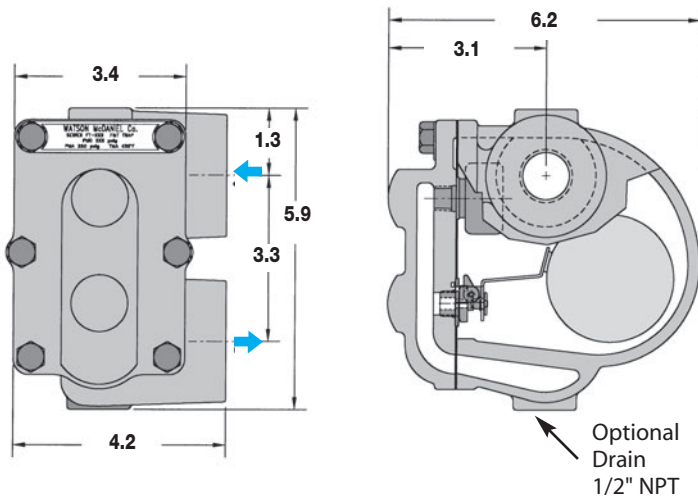

SPECIFICATIONS

Model	Sizes	Connection	PMO (PSIG)	PMA (PSIG)	Weight (lbs)
WFT-15	3/4", 1", 1 1/4"	NPT	15	125	9
WFT-30	3/4", 1", 1 1/4"	NPT	30	125	9
WFT-75	3/4", 1"	NPT	75	125	9
WFT-125	3/4", 1"	NPT	125	125	9

SPECIFICATIONS

Model	Sizes	Connection	PMO (PSIG)	PMA (PSIG)	Weight (lbs)
WFT-175	3/4", 1"	NPT	175	250	20
WFT-250	3/4", 1"	NPT	250	250	20

Use 3/4" F&T traps for drip applications up to 125 PSIG

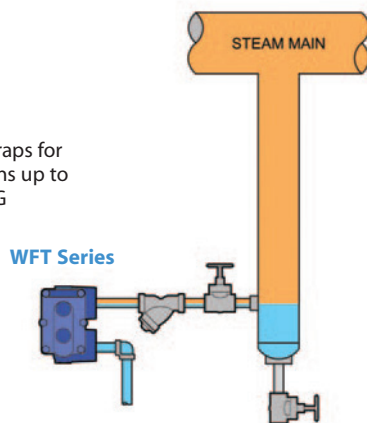

Steam Main Drip Application

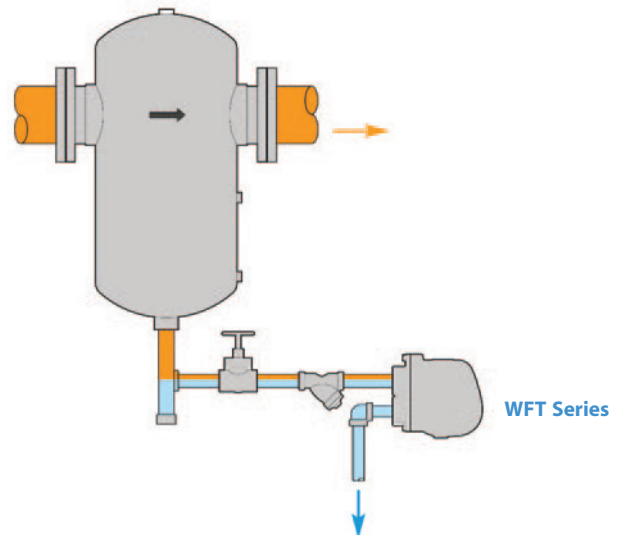

Separator Application

Steam Traps

Float & Thermostatic Steam Trap

WFT Series

Float & Thermostatic

STEAM TRAPS

Dimensions: inches



WFT
1 1/4" & 1 1/2"



WFT
2"

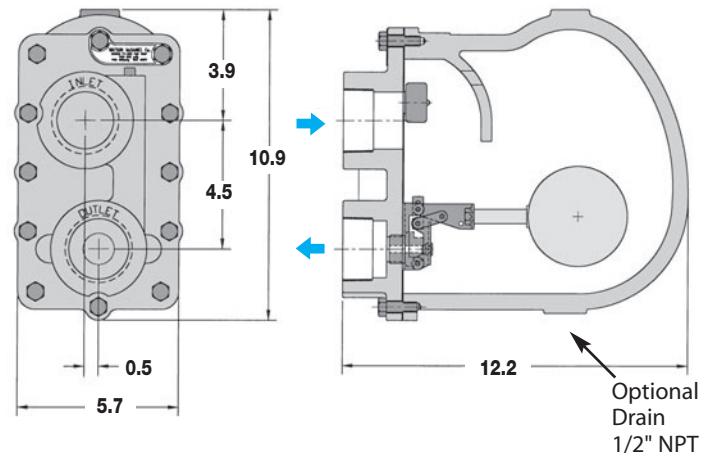
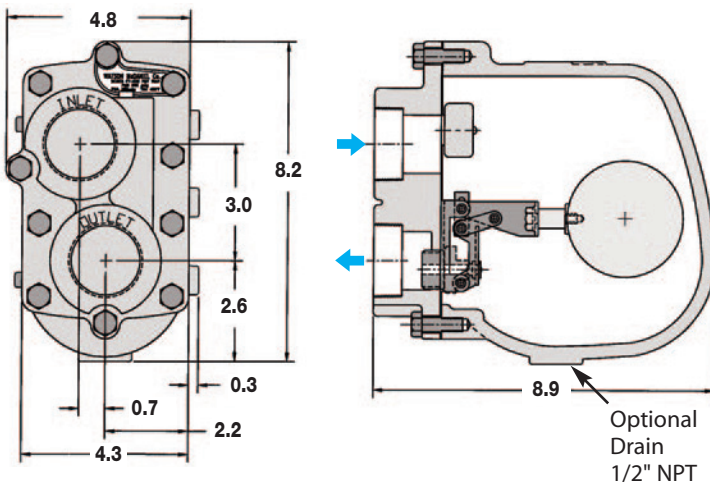

SPECIFICATIONS					
Model	Sizes	Connection	PMO (PSIG)	PMA (PSIG)	Weight (lbs)
WFT-15	1 1/2"	NPT	15	250	21
WFT-30	1 1/2"	NPT	30	250	21
WFT-75	1 1/4", 1 1/2"	NPT	75	250	21
WFT-125	1 1/4", 1 1/2"	NPT	125	250	21
WFT-175	1 1/4", 1 1/2"	NPT	175	250	21
WFT-250	1 1/4", 1 1/2"	NPT	250	250	21

SPECIFICATIONS					
Model	Sizes	Connection	PMO (PSIG)	PMA (PSIG)	Weight (lbs)
WFT-15	2"	NPT	15	250	53
WFT-30	2"	NPT	30	250	53
WFT-75	2"	NPT	75	250	53
WFT-125	2"	NPT	125	250	53
WFT-175	2"	NPT	175	250	53
WFT-250	2"	NPT	250	250	53

Multi-bank Air Heating Coils / Air Handler Unit

